

Speake & Co Limited  
Distributed in the United States by: Fat Quarters Software  
24774 Shoshonee Drive, Murrieta, California 92562  
Tel: 951-698-7950 Fax: 951-698-7913

## **FGM-series** **Magnetic Field Sensors**



# Application Note

## **High Sensitivity Gradiometer - Magnetic Anomaly Detection**

This note describes the use of a dedicated IC chip, the SCL007, intended to provide the essential electronics for the construction of two-sensor type gradiometers.

While small magnetic field changes can be readily detected with a single static sensor, as in the case of an earth field magnetometer, the very presence of the large earth field presents an immediate problem if the sensor is to be moved. A small change in angle will give a signal which is likely to be many times larger than the field magnitude variations that are being looked for as anomalies.

The gradiometer principle is based on the fact that, in a uniform field, two identical and perfectly aligned sensors will give identical outputs which can be subtracted from one another to give a zero output, effectively eliminating the apparent presence of the field. Provided the sensors remain solidly fixed in relation to one another, the whole assembly can be rotated in space without producing any orientational output. If, however, there is a superimposed small field gradient as well as the uniform field, the output of the subtracted sensor combination will change as a function of the magnitude and direction of that gradient. Such gradients arise from the presence of anomalous magnetic moments within the capture range of the gradiometer.

These anomalies may arise from a great many causes, varying from the tiny firing pin of a plastic land-mine buried only a few inches under the surface, to a large marine wreck on the sea bed. The apparent capture range also varies enormously since it depends on the magnetic moment of the anomaly. A small pole strength coupled with a very large object can produce a large magnetic moment, giving a correspondingly large capture range. Conversely even a large pole strength in a very small object can give rise to a very limited capture range. A typical example of the latter is the modern flat ceramic type of magnet which is magnetised through its thickness rather than along its larger dimension. Such magnets seem very powerful in their grip but produce very small fields at a distance.

The distance between the two sensors depends on the distance at which an object of interest is to be detected, and its magnetic moment. This spacing should be determined by experiment. For small targets within 2 feet of the nearest sensor, try a sensor spacing of 18 inches.

In practice no two sensors are ever identical and measures must be taken to eliminate their zero-field offsets and to match their sensitivities. In practice this is not too difficult to do electronically, if an initial calibration routine is adopted on switch-on. This can be semi-automatic and requires only a simple manual manipulation. It is more difficult however to guarantee the identical alignment of the sensor axes in the mechanical sense and for accurate instruments some adjusting mechanism will be required. This type of adjustment should fortunately not be necessary at every start-up and should remain accurate if the gradiometer is constructed from stable materials.

One method of arranging for this alignment is to build the gradiometer in a tube of diameter somewhat larger than that of the sensors. One sensor is fitted permanently into one end of the tube with appropriate packing to hold it securely. The other sensor is fitted to the opposite end of the tube but only held at one of its ends by some sort of flexible mount such as a snugly fitting O-ring. Four adjusting (non magnetic ) screws can be fitted at right angles around a circumference of the tube to force the non-clamped end of the sensor to tilt slightly in the required direction.

The basic idea is illustrated in the diagram below.

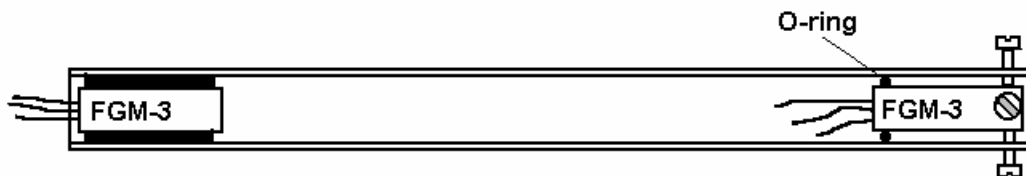

### Basic Gradiometer Construction

The position of the set screws can only be determined by experiment, the objective being to reduce to a minimum the variation of output ( after electronic calibration ) observed when the gradiometer is rotated freely in space.

One technique for doing this is to place the gradiometer tube in Vblocks in an approximately horizontal east-west direction and gently rotate the tube about its axis. Since the earth's field should be at right angles to both sensors in this configuration any misalignment of the sensors should result in a sinusoidal variation of output with rotation, giving a clue as to the required direction of adjustment.

A further source of potential error is the possibility that the sensors may not have identical non-linearities. This is less easy to overcome but an improvement in performance is possible in most cases by adopting an appropriate usage technique. It will vary with the application but consists basically of trying always to hold the gradiometer in the same orientation when making measurements. For accurate measurements, where speed is not the prime requirement one good way of doing this is to suspend the tube vertically from a simple pivot allowing gravity to guarantee the repeatable alignment. In this way the gradiometer can be moved over a large grid, for example, to allow the plotting of contours of gradient in a search for underground anomalies.

Earth anomalies usually show up best in the vertical orientation, which is probably why oil companies and archaeologists make use of the vertical vector in their studies.

For simpler less accurate systems used with short ranges, for example metal detectors, it may be enough to simply maintain a constant orientation by hand and eye coordination.

The pin layout can be seen in the schematic diagram below.

Pin 1 is an input giving two different sensitivities when set either high or low. The two sensitivities, controlled by pin 1 differ by a factor of eight to provide a range for larger field anomalies.

Pin 2 is an output pin which provides a polarity signal as part of the output, which should therefore be regarded as a signed magnitude, rather than the usual twos complement. This gives an extra bit of precision to the reading by effectively making the output a total of nine bits.

Pins 17 and 18 are the sensor inputs and accept the 5 volt output pulses directly.

Pins 15 and 16 are for a crystal circuit to give a stable reference to measure the sensor period variations against.

The remaining pins are the digital output bits, D0 to D7 for use by external equipment or displays. D0 =LSB, D7=MSB

The system performs an auto calibration during the first ten to twenty (dependent on crystal frequency) seconds after switch on, during which it expects to see the maximum and minimum value of the earth's field. The best way to do this is to hold the gradiometer in a north-south orientation pointing upwards at about the angle of the field's inclination, (in the UK about 67° to the horizontal in the north/south direction) then switch on and rotate the gradiometer through 180° to directly reverse its direction, during the ten seconds after switch on. It is best not to do this any more hastily than necessary.

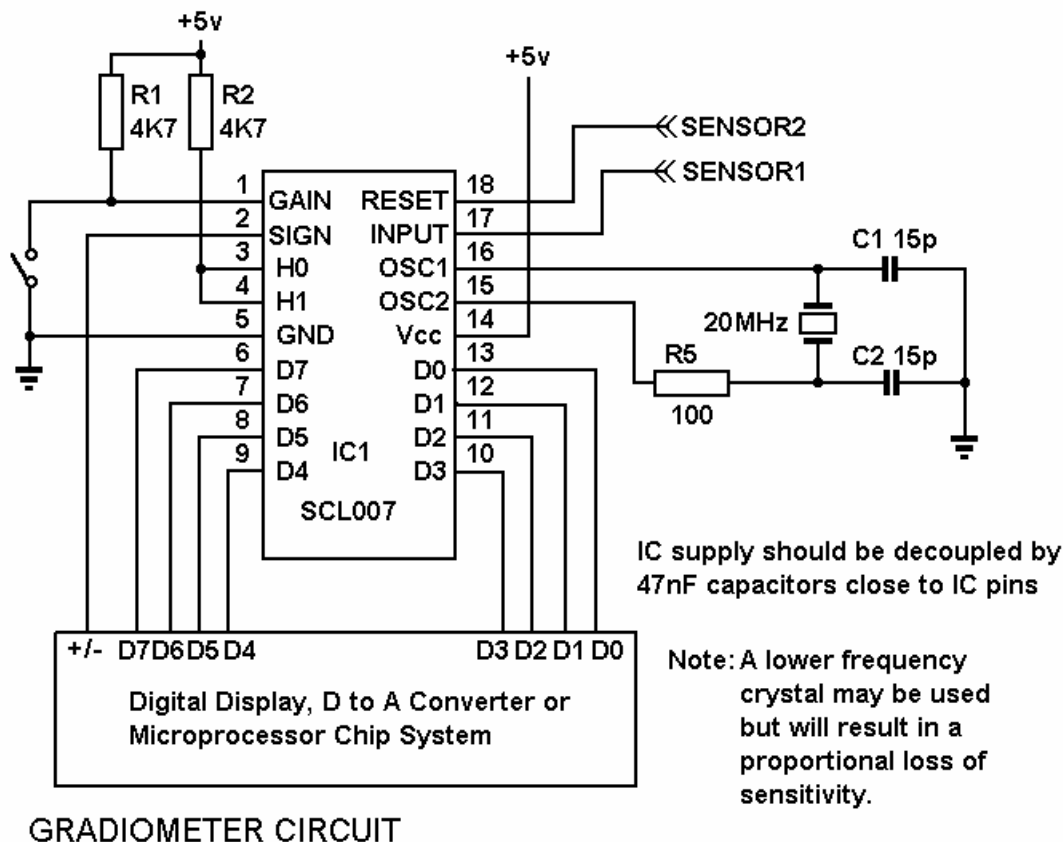

After this the system will determine the sensitivity and the zero offset for each sensor separately and correct for the errors, which would arise through sensor differences, during the signal subtraction process. It should then be possible to rotate the gradiometer slowly in any direction without getting too much output if there are no field anomalies at the location. It should be done slowly because the sensors are time multiplexed and rapid movement will beat the system to some extent.

A little practice at this technique will soon get the best cancellation and the process can be repeated as often as necessary to optimise the balance. Also for the best observations it is obviously advantageous to always have the sensor in the same orientation during the taking of readings. You can test the success of the set-up by approaching the gradiometer with a permanent magnet as the local anomaly. The size of the anomaly will be a function of the moment of the magnet which is a function of its magnetic length.

One other point is worth mentioning. If you adopt the suggestion of hanging the gradiometer vertically, then it is an advantage to hang it from the end that makes the wires from each sensor emerge in the downward direction.

Two sensors which share the same 5 volt regulated power supply line impedance can give rise to a tendency for the individual sensors to frequency lock together when their output frequencies are within a few hundred Hertz of one another. This can be eliminated by decoupling capacitors fitted close to each sensor's +5V and Ground pins. Tantalum or electrolytic capacitors of 22 to 47 uF will be adequate. In addition to the capacitors, more effective decoupling is obtained by running each sensor's power and ground leads separately back to the source in order to minimise a common power supply and ground impedance.

Best results have been obtained using a rigid non-metallic pipe to mount the two sensors in. One method to increase the rigidity of plastic pipe, is to slide a tight fitting piece of aluminum angle stock into the pipe after first mounting the sensors on it. Alternatively, the pipe itself may be fastened to a larger piece of angle stock exterior to the pipe. A close fitting copper or aluminum pipe may degrade sensor performance by acting as a "shorted turn" to the sensor's internal oscillator. Under no circumstances should an iron or steel pipe be used as this would severely limit the sensitivity of the gradiometer.